

Rec. ceiling hole: $\varnothing 139 - 142$ mm

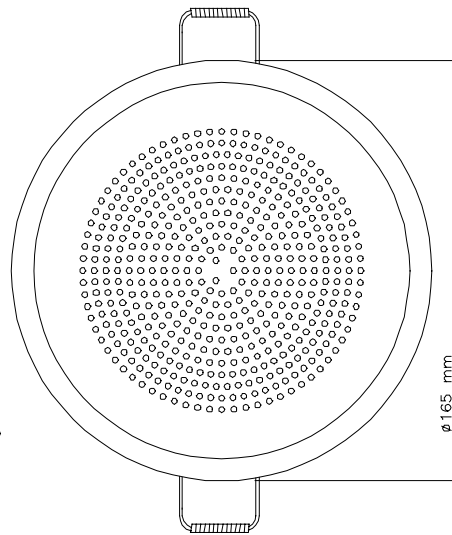
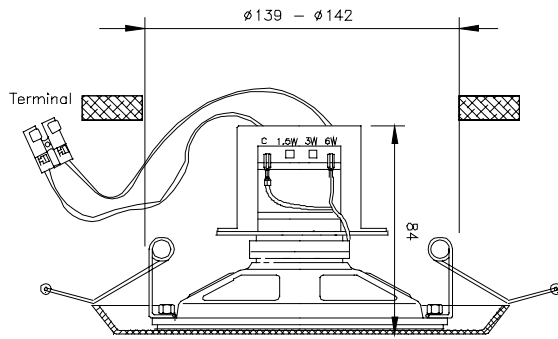

Transformer:
100 Volt line
White : Black 100V

Secondary nominal
tappings:

common : 4	6,0W
common : 3	3,0W
common : 2	1,5W

1W/1m Pink Noise 1/3 octave bands

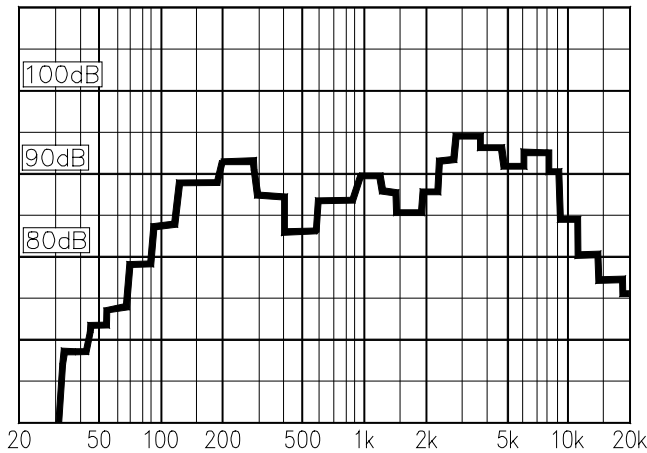

Material / Colour	Aluminium / RAL9010
Mounting	Springs
Termination	Spring clamps
Weight	0,5 kg
IP-rating	
Max. / min. amb. temp	90°C / -20°C
Standard version	100 V transformer
Rated / max. power	6 W
SPL 1W/1m	90 dB
SPL rated power	97 dB
Effective freq. range	110 – 15000 Hz
Dispersion (-6dB) 1kHz / 4kHz	170° / 60°

Installation, Operation and Maintenance Procedures

- Connect to terminal. Install loudspeaker grill by bending back 2 springs.
- For optimum performance, always use the correct voltage / power and operate within the frequency limits as stated.
- Take care when loudspeaker is energized (100 V).
- This loudspeaker is supplied with a 2 year warranty against defective workmanship.

Most of our products are available in different colours, impedances and power ratings.

