

Bracket and all outside nuts and screws in stainless steel.

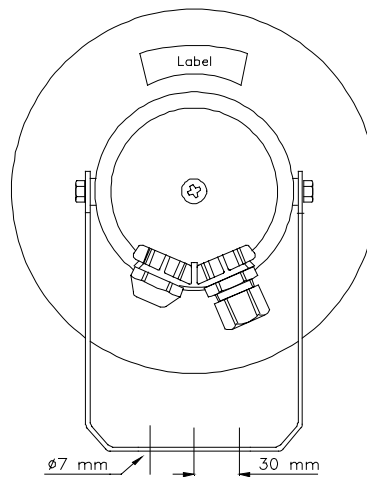
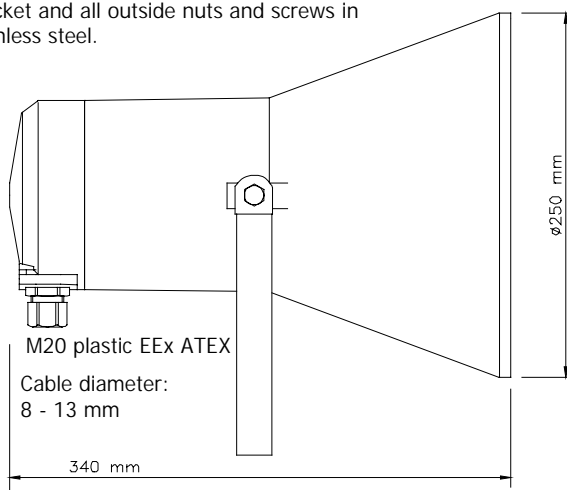

Transformer:
100 Volt line

Primary nominal
tappings:
1 : 2 25,0 W
2 : 3 12,5 W
3 : 4 6,0 W
1 : 3 4,0 W
2 : 4 2,0 W
1 : 4 1,0 W

Certified by / Certification code / Number: NEMKO / EEx de IIB+H2 T5 / 01 ATEX 238



1W/1m Pink Noise 1/3 octave bands

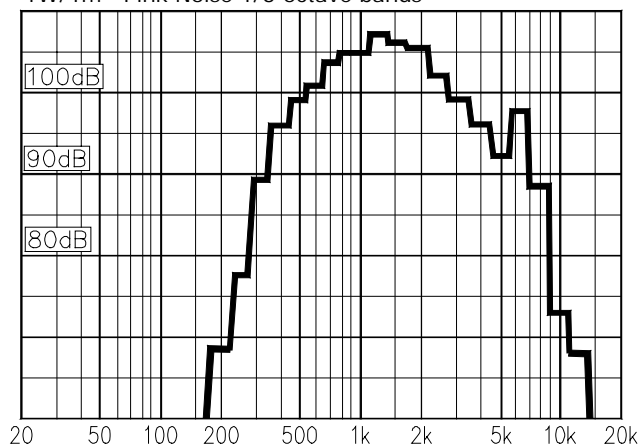

Material / Colour..... Anti-static polyamide / black
 Mounting Bracket
 Termination e-chamber, screw terminals
 Weight 4,0 kg
 IP-rating..... 66
 Max. / min. amb. temp 40 °C / -50 °C
 Standard version 100 V transformer
 Rated / max. power 25 W / 25 W
 SPL 1W/1m..... 106 dB
 SPL rated power..... 117 dB
 Effective freq. range 370 – 7000 Hz
 Dispersion (-6dB) 1kHz / 4kHz..... 110° / 30°
 Directivity factor, Q.....

Installation, Operation and Maintenance Procedures

- When mounting the loudspeaker please ensure that it is re-assembled in the same manner in which it was received.
- To change the position of the loudspeaker please adjust the bracket (by loosening / tightening the screws) as required.
- For optimum performance, always use the correct voltage / power and operate within the frequency limits as stated.
- Use only certified/specified cable glands and blanking plugs.
- Do not open loudspeaker when energized.
- The loudspeaker should be checked on a regular basis to avoid any build up of debris.
- Fasten lid with a torque of 2 - 3 Nm.
- This loudspeaker is supplied with a 2 year warranty against defective workmanship.

Most of our products are available in different colors, impedances and power ratings.

