



# DNH<sup>AS</sup>

N-3770 Kragerø  
NORWAY  
Phone: ..... (47) 35 98 56 00  
Fax: ..... (47) 35 98 56 10  
E-mail: ..... dnh@dnh.no  
Web-site: ..... [www.dnh.no](http://www.dnh.no)

ISO 9001 CERTIFIED

## HS-15 ExdFM(T)

**DNH WW Ltd. England** Phone: ..... (44) 1908 275 000  
Fax: ..... (44) 1908 275 100  
E-mail: ..... dnh@dnh.co.uk  
**DNH GmbH Germany** Phone: ..... (49) 040 6569 30-0  
Fax: ..... (49) 040 6569 30-30  
E-mail: ..... dnh@dnh.de

Bracket and all outside nuts and screws in stainless steel.

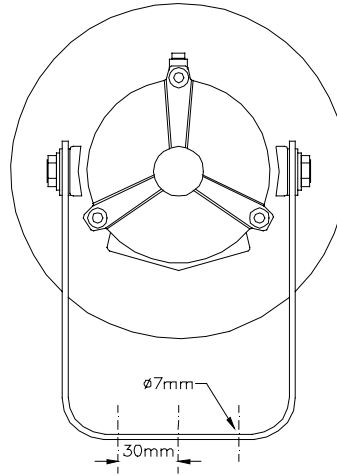
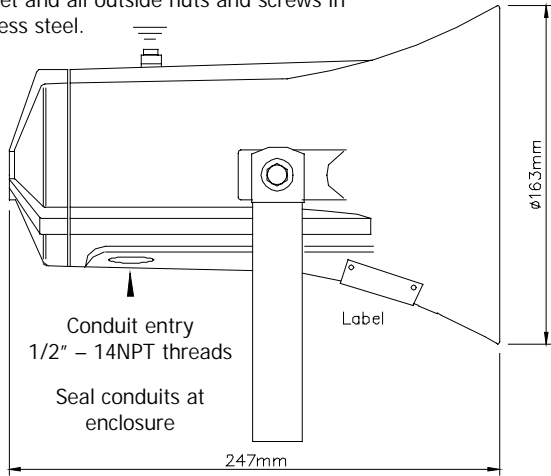

Transformer:  
100 V line

Primary nominal  
tappings:

1 : 2    15,0 W  
2 : 3    7,5 W  
3 : 4    4,0 W  
1 : 3    2,7 W  
2 : 4    1,3 W  
1 : 4    0,8 W

1 = Red, 2 = Yellow  
3 = Green, 4 = Blue

Certified by / Certification code:      Factory Mutual approved – Class I, Div. 1, Groups B, C and D  
(Not including acidic atmospheres)



APPROVED

1W/1m Pink Noise 1/3 octave bands



Material / Colour.....Aluminium alloy (LM-6) / RAL 7031  
Mounting ..... Bracket  
Termination ..... Screw terminals  
Weight ..... 2,8 kg  
IP-rating ..... 67  
Max. / min. amb. temp ..... 40 °C / -20 °C  
Standard version ..... 100 V transformer  
Rated / max. power ..... 15 W / 15 W  
SPL 1W/1m..... 104 dB  
SPL rated power ..... 116 dB  
Effective freq. range ..... 410 – 7000 Hz  
Dispersion (-6dB) 1kHz / 4kHz ..... 140° / 40°  
Directivity factor, Q.....

### Installation, Operation and Maintenance Procedures

- When mounting the loudspeaker please ensure that it is re-assembled in the same manner in which it was received.
- To change the position of the loudspeaker please adjust the bracket (by loosening / tightening the screws) as required.
- For optimum performance, always use the correct voltage / power and operate within the frequency limits as stated.
- Use only certified/specified cable glands and blanking plugs.
- Do not open loudspeaker when energized.
- The loudspeaker should be checked on a regular basis to avoid any build up of debris.
- Fasten lid with a torque of 2 - 3 Nm.
- Ex-loudspeakers must be earthed correctly using the specially marked screws.
- This loudspeaker is supplied with a 2 year warranty against defective workmanship.

Most of our products are available in different colors, impedances and power ratings.



DNH reserves the right to alter specifications without notice.

Rev. 19.09.2000